

Amazing speed that sets the standard

SRA166/210

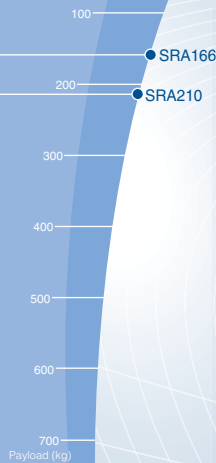

World Class Speed Robot

- Robot motion makes minimum cycle times unbeatable. Light weight and high rigidity design results in high acceleration and minimum vibration. Maximum speed on all axes reduces move time. All this provides dramatically improved productivity.

SRA robot ease of use improves the bottom line

- Improved drives and motors for accurate positioning and better repeatability.
- Slim and compact design allows closer installation in less floor space.
- Maintainability is improved with easier inspections and parts replacement.

Improved energy efficiency

- Power consumption reduced 15% from existing models by reducing the robot's weight by 20% and using cutting edge motor drive controls.

SRA166/210

◆ Robot specifications

Item		Specifications	
Robot model		SRA166-01	SRA210-01
Structure		Articulated construction	
Number of axes		6	
Drive system		AC servo system	
Max. operating area	Arm	J1 Swivel	±3.14 rad (±180°)
		J2 Forward/backward	+1.05~−1.40 rad (+60°~−80°)
		J3 Upward/downward	+2.62~−2.56 rad (+150°~−146.5°)
	Wrist	J4 Rotation2	±6.28 rad (±360°)
		J5 Bending	±2.36 rad (±135°) ±2.27 rad (±130°)
		J6 Rotation1	±6.28 rad (±360°)
Max. velocity	Arm	J1 Swivel	2.18 rad/s (125°/s) 2.01 rad/s (115°/s)
		J2 Forward/backward	2.01 rad/s (115°/s) 1.83 rad/s (105°/s)
		J3 Upward/downward	2.11 rad/s (121°/s) 1.97 rad/s (113°/s)
	Wrist	J4 Rotation2	3.14 rad/s (180°/s) 2.44 rad/s (140°/s)
		J5 Bending	3.02 rad/s (173°/s) 2.32 rad/s (133°/s)
		J6 Rotation1	4.54 rad/s (260°/s) 3.49 rad/s (200°/s)
Payload	Wrist	166 kg	210 kg
	Forearm*1	45 kg (maximum 90kg)	
Allowable static load torque	J4 Rotation2	951 N·m	1,337 N·m
	J5 Bending	951 N·m	1,337 N·m
	J6 Rotation1	490 N·m	720 N·m
Max. allowable moment of inertia*2	J4 Rotation2	88.9 kg·m ²	141.1 kg·m ²
	J5 Bending	88.9 kg·m ²	141.1 kg·m ²
	J6 Rotation1	45.0 kg·m ²	79.0 kg·m ²
Position repeatability*3		±0.1 mm	±0.15 mm
Ambient temperature		0~45 °C	
Installation		Floor mounted	
Robot mass		960 kg	990 kg

1[rad] = 180/π[°], 1[N·m] = 1/9.8[kgf·m]

*1 : Load specification of number 1 arm varies according to wrist load conditions and installation position.

*2 : Note that the allowable moment of inertia of wrist varies with the wrist load conditions.

*3 : JIS B 8432 compliant.

◆ Exterior dimensions and operating envelope

SRA166/210-01

* Data shown in for SRA210-01.

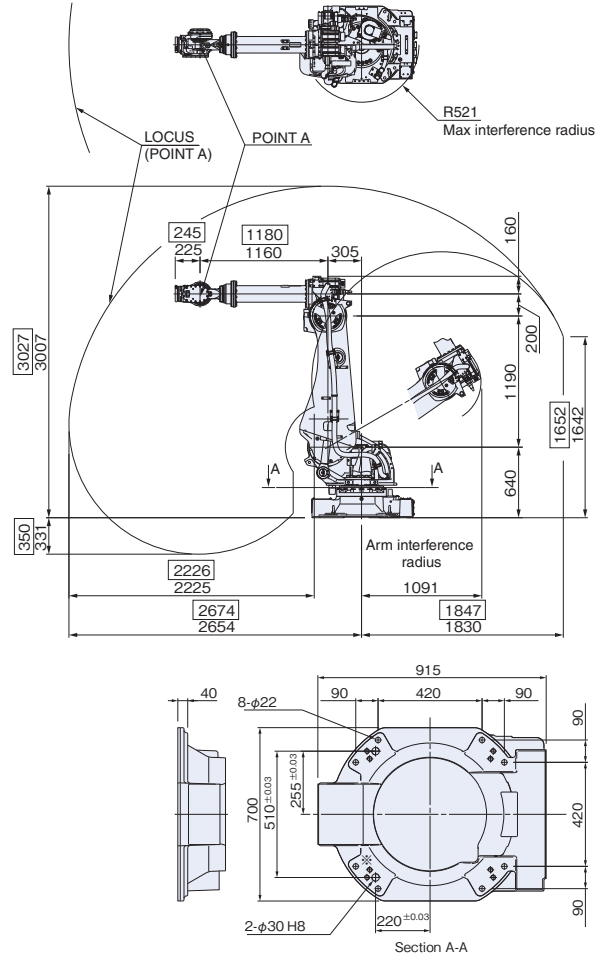

SRA166-01

SRA210-01

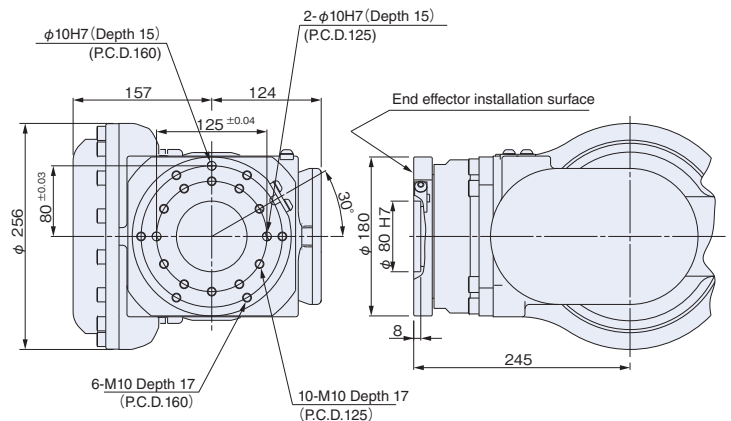
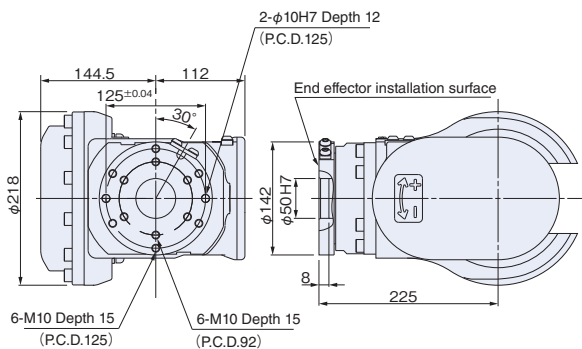

● The specifications are subject to changes without notice.

● In case that an end user uses this product for military purpose or production of weapon, this product may be liable for the subject of export restriction stipulated in the Foreign Exchange and Foreign Trade Control Law. Please go through careful investigation and necessary formalities for export.

NACHI-FUJIKOSHI CORP.

Tokyo Head Office

Shiodome Sumitomo Bldg. 17F 1-9-2 Higashi-shinbashi,
Minato-ku, Tokyo 105-0021, JAPAN
Tel: +81-(0)3-5568-5245 Fax: +81-(0)3-5568-5236

Toyama Head Office

1-1-1 Fujikoshi-Honmachi, Toyama 930-8511, JAPAN
Tel: +81-(0)76-423-5111 Fax: +81-(0)76-493-5211

NACHI ROBOTIC SYSTEMS INC.

22285 Roethel Drive, Novi, Michigan, 48375, U.S.A.
Tel: +1-248-305-6545 Fax: +1-248-305-6542

URL: <http://www.nachirobotics.com/> E-mail: Marketing@NachiRobotics.com

NACHI EUROPE GmbH

Bischofstrasse 99, 47809, Krefeld, GERMANY
Tel: +49-(0)2151-65046-0
Fax: +49-(0)2151-65046-90

URL: <http://www.nachi.de/>

NACHI-FUJIKOSHI CORP. THAILAND REPRESENTATIVE OFFICE

Unit 23/109(A), Fl.24th Sorachai Bldg., 23 Sukhumvit 63 Road(Ekamai), Klongtonnua, Wattana,
Bangkok 10110, THAILAND
Tel: +66-2-714-0008 Fax: +66-2-714-0740

CATALOG NO.

R7201E

2011.11.V-ABE-ABE